

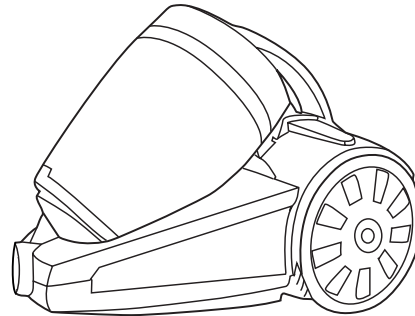

**morphy richards®**



## **PerformAir Endurance bagless cylinder vacuum cleaner**

 Please read and keep these instructions

### **Getting the best from your new cleaner...**

*If your cleaner is not picking up as well as it should, please check*

#### **Filters**

*It is important to rotate the filter dial prior to emptying.*

*This action shakes clean the dust canister pleated filter. See page 6.*

#### **Blockages**

*Check the nozzle, tubes and hose for blockages.*

#### **Turbo nozzle** *(certain models only)*

*Remove hair and dirt caught around the brush bar regularly.*

#### **Safety cut out**

*If the product switches itself off during use, refer to page 7 for instructions.*



To register for your 3 year guarantee, ring the Helpline numbers below **within 28 days of purchase**. This offer is only available in the UK.

Please have the following information available:

Serial number:

Model number:

(see page 8 for guarantee details).



For replacement parts, help with using your Morphy Richards, problems and lots more, contact us by phone or through our website.

VC71067 MUK Rev 2



**UK Helpline: 0845 077 7700**  
**Ireland 1800 409 119**

[www.morphyrichards.com](http://www.morphyrichards.com)

## **IMPORTANT SAFETY INSTRUCTIONS**

The use of any electrical appliance requires the following common sense safety rules.

Primarily there is danger of injury or death and secondly the danger of damage to the appliance. These are indicated in the text by the following two conventions:

### **WARNING: Danger to the person!**

IMPORTANT: Damage to the appliance!

In addition we offer the following safety advice.

Please read before using the appliance

## **Location**

- Do not use or keep this product outside.
- Do not store the appliance near hot surfaces eg. ovens or heating appliances.

## **Mains lead**

- Do not allow the mains lead to become strained or run this appliance over it.
- If the electrical cable becomes damaged the cable assembly must be replaced. Do not attempt this task yourself, contact the helpline number that is found at the bottom of the page.

## **Personal safety**

- The plug must be removed from the wall socket before cleaning or maintaining the appliance.

- Never modify the cleaner in any way.
- Never use in the presence of explosive liquids or vapours.
- Never pick up inflammable or poisonous liquids such as petrol, copier toner or other volatile substances. Never pick up acids, asbestos or asbestos dust.
- Repairs to electrical appliances are only to be undertaken by trained personnel. Unprofessional repairs can be dangerous for users.
- Use only genuine Morphy Richards spare parts and accessories.
- The appliance must never be left running when unsupervised.
- This vacuum cleaner is intended for domestic use only. Misuse or use for commercial or any other purpose will render the guarantee invalid.
- This appliance is not intended for use of persons (including children) with reduced physical, sensory or mental capabilities, or lack of experience and knowledge, unless they have been given supervision or instruction concerning use of the application by a person responsible for their safety.

## **Product safety**

- Never use the appliance without the filters being installed.
- Never use the appliance to vacuum hot ashes, broken glass, sharp objects or liquids.

## **Children**

- Children do not understand the dangers associated with operating electrical appliances. Never allow children to use this appliance.
- Children should be supervised to ensure that they do not play with the appliance, or stumble over the power cord.

## **ELECTRICAL REQUIREMENTS**

Check that the voltage on the rating plate of your appliance corresponds with your house electricity supply which must be A.C. (Alternating current).

If the socket outlets in your home are not suitable for the plug supplied with this appliance the plug should be removed and the appropriate one fitted.

If you cut off the plug and let go of the cable it will rewind into the machine therefore you must pull out a length of cable and secure it before cutting the plug off and re-fitting a new one.

**WARNING: The plug removed from the mains lead, if severed, must be destroyed as a plug with a bared flexible cord is hazardous if engaged into a live socket outlet.**

Should the fuse in the 13 amp plug require changing a 13 amp BS1362 fuse must be fitted.

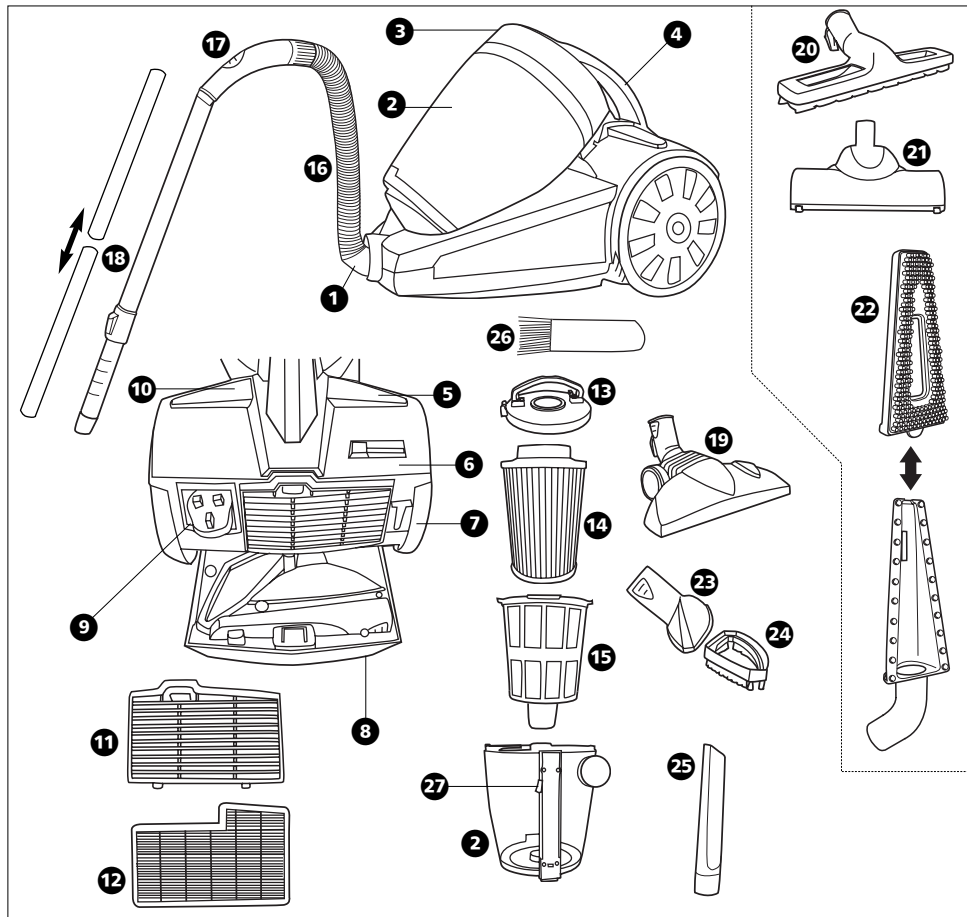

## FEATURES

- |                                |   |  |
|--------------------------------|---|--|
| 1 Hose inlet                   | 11 Exhaust filter grille  | 20 Hard floor nozzle (certain models only)               |
| 2 Dust canister                | 12 Exhaust filter   | 21 Turbo nozzle (certain models only)                    |
| 3 Dust canister release button | 13 Dust canister lid  | 22 Hair and Stair tool (certain models only)             |
| 4 Carrying handle              | 14 Pleated, washable dust canister filter   | 23 Upholstery nozzle                                     |
| 5 On/off power switch          | 15 Mesh filter cover  | 24 Clip on brush (attached to 23)                        |
| 6 Eco Switch                   | 16 Hose   | 25 Crevice tool  |
| 7 Parking slot                 | 17 Hose handle with airflow regulator   | Note: 23, 24, 25 are stored in the tool storage drawer 8 |
| 8 Tool storage drawer          | 18 Tube(s): 2 separate attachable tubes, or 1 single telescopic tube (length adjustable), dependant on model. | 26 Filter cleaning brush                                 |
| 9 Plug recess                  | 19 Combination floor nozzle   | 27 Dust canister lid release                             |
| 10 Cable rewind switch         |   |  |

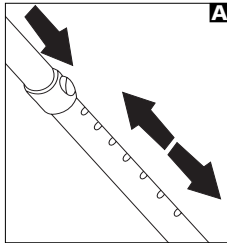

## OPERATING THE APPLIANCE

### TOOLS AND ACCESSORIES

**1** Fit the hose to the cleaner by inserting the hose end into the hose inlet **1**. When removing, squeeze the clips either side and pull.

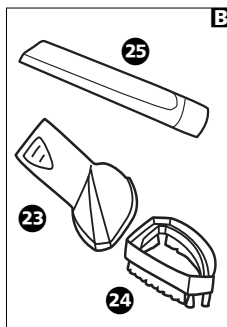

**2** Attach the tube(s): either the 2 separate attachable tubes, or the single telescopic tube (dependant on model).

- For the telescopic tube, extend to the required length by pushing up the slider release and pulling out the tube **A**.
- The hose handle features an airflow regulator which allows suction to be reduced as required.

**3** Attach your choice of floor nozzle to the end of the tube **18**.

### Combination floor nozzle

The combination floor nozzle can be adjusted to suit different floor surfaces. Retract the brushes for use on carpet. The brushes should be down for use on hardfloors or damage may occur.

### Hand tools

The crevice tool **25** (for awkward places, behind radiators etc) and the upholstery nozzle **23** with clip on brush **24** (for curtains and upholstery) are stored in the tool drawer **8** **B**.

### Using the turbo nozzle

(certain models only)

Attach the turbo nozzle **21** to the telescopic tubes.

This nozzle is ideal for carpet and especially effective at removing pet hair.

### Cleaning the turbo nozzle

The turbo nozzle should be regularly cleaned and any hairs or fibres wrapped around the brush bar removed to maintain optimum performance.

### Hardfloor nozzle

(certain models only)

Attach the hardfloor nozzle **20** to the telescopic tubes. This nozzle is ideal for use on wood, laminate, tile and vinyl flooring.

### Hair and Stair tool

(certain models only)

This tool **22** is suitable for cleaning the stairs, and when the additional attachment is added, it is ideal for picking up human and pet hair.

### Quick guide to accessories:

	Combination floor nozzle	Turbo nozzle	Hair and Stair tool	Hard floor nozzle	Crevice tool	Upholstery nozzle with clip on-brush
Carpet	✓ With brushes retracted	✓				
Rugs	✓ With brushes retracted	✓				
Wood/laminate	✓ With brushes down			✓		
Tile	✓ With brushes down			✓		
Vinyl	✓					
Upholstery			✓	✓	✓	✓
Stairs			✓			✓
Small spaces					✓	

### CONTROLS

#### Power

- 1 Assemble with the required hose, tube and accessory
- 2 Pull out the mains cable to it's full length and plug into the mains supply.
- 3 Switch on by pressing the on/off power switch **5**.

#### Eco Switch

The Eco Switch **6** allows you to turn down the power when cleaning more delicate items such as curtains and upholstery, saving energy and reducing running costs.

Suction can also be controlled using the airflow regulator on the hose handle. Closed for maximum suction, open for reduced suction.

#### Automatic cable rewind

After use, unplug and press the cable rewind switch to retract the cable.

**WARNING: When using the cable rewind, always hold the plug as the cable will rewind quickly.**

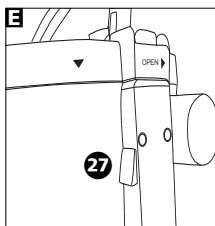
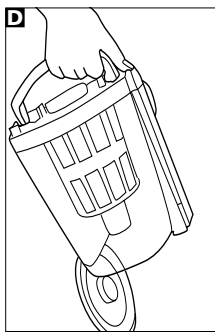
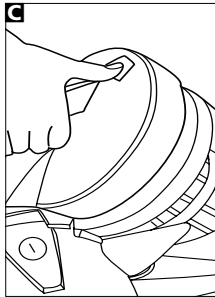

## DUST CANISTER

### Emptying

To obtain the best results from your cleaner empty the dust canister regularly, otherwise the airflow and cleaning power will be reduced.

- 1 Every time the dust canister is emptied, turn the yellow dial (a minimum of 5 revolutions) prior to pressing the dust canister release button (this will agitate the fine dust between the filter pleats and restore the air flow)
- 2 Remove the dust canister from the product by pressing the dust canister release button **3**. Lift up the lid and remove the canister from the product, pulling the dust canister away from the product. **C**
- 3 Holding the dust canister over a dustbin press the dust release button as shown **D**, the bottom of the dust container will drop down to release the dirt.
- 4 Close the bottom of the dust canister by pressing the base upwards until it clicks into place.
- 5 Refit the dust canister back into the product. Make certain the dust canister feet are located in place.
- 6 Close the lid securely.

## ALLERGY SUFFERERS

When emptying any vacuum cleaner, it is difficult to avoid exposure to dust. To minimise this risk, please ensure that you encase the dust canister in a large bag to empty it. Close the bag as tightly as possible round the dust canister. Remove the dust canister and close the bag as tightly and quickly as possible and dispose of this immediately. It is advisable to wear disposable gloves and a face mask while emptying the cleaner. If at all possible, ask a non allergy sufferer to empty the dust canister when required.

## FILTERS

### Cleaning canister filter

- 1 Access the filter assembly by removing the lid **15**. Press the lid release button **27** down then rotate the lid anti-clockwise **E**.
- 2 Use the filter cleaning brush to remove any fluff from the outside of the mesh filter.
- 3 Rotate mesh filter clockwise to disassemble the filters.
- 4 Shake the pleated filter to remove any dust.
- 5 Both the mesh and pleated filters may be washed (in cool water only) but must be thoroughly air dried before refitting.

**IMPORTANT:** Do not use detergents to clean the filters.

- A spare pleated filter is provided. This allows one to be in use whilst the other is washed and dried.
- 6 To re-assemble, locate the pleated filter into the lid then secure into place with the mesh filter by rotating the mesh filter anti-clockwise.
  - 7 Fit the lid with filter assembly onto the canister then rotate clockwise until it locks into place.

### Exhaust filter

The exhaust filter ⑫ is located at the rear of the cleaner. Press the catch and pull the exhaust grille ⑪ away ⑫. Pull the bottom of the filter outwards so the top of the filter unhooks from the filter recess.

To maintain the high efficiency, the exhaust filter should be replaced every 6 months.

**IMPORTANT:** To re-fit the filters, first hook the top of the filter into the filter recess then push the bottom of the filter into location ⑬.

Note: If the filter is not correctly hooked in, the exhaust filter grille will not close.

After fitting the filter, re-fit the exhaust filter grille by hooking the bottom of the grille in first and then pushing the top close until it clicks fully closed.

**IMPORTANT:** All filters should be checked regularly for signs of damage, preferably after each cleaning task. The filters must be replaced immediately if they become damaged.

- Always disconnect the cleaner from the mains when checking filters.
- Always make sure all filters are fitted before use. Failure to do so may result in damage to your product.

### Storage position

When finished you can store the tubes and accessories by locating the tube storage clip into the parking slot on the side of the cleaner as shown ⑭.

### Safety cut-out

If the cleaner overheats a motor protection thermostat will automatically switch the motor off. If this happens, switch the cleaner off, unplug from the power supply and leave the cleaner to cool for at least 60 minutes. Check the airways for blockages, empty dust canister and clean the filters before restarting.

### Cleaning and maintenance

Unplug from the mains before cleaning. The vacuum cleaner, especially the dust compartment and all accessories can be cleaned using a damp cloth or a non-abrasive cleaner and wiped dry.

### Purchasing replacement filters

Use only original Morphy Richards filters. These can be purchased from Morphy Richards on Replacement parts line.

### HELPLINE

If you have any difficulty with your appliance, do not hesitate to call us.

**We are more likely to be able to help than the store from where you bought it.**

Please have the following information ready to enable our staff to deal with your query quickly.

- Name of the product
- Model number as shown on the underside of the appliance.
- Serial number as shown on underside of the appliance.

**UK Helpline 0845 077 7700**

**Ireland Helpline 1800 409 119**

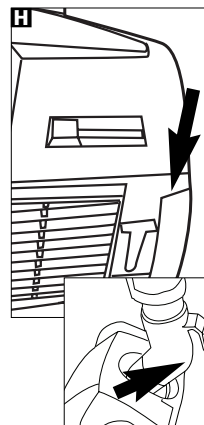
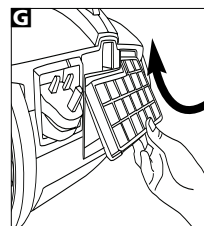
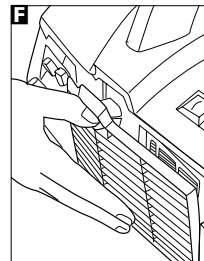

For electrical products sold within the European Community. At the end of the electrical products useful life it should not be disposed of with household waste. Please recycle where facilities exist. Check with your Local Authority or retailer for recycling advice in your country.

## YOUR THREE YEAR GUARANTEE

Available on registration in the UK only



This 3 year guarantee is only valid when registered directly with Morphy Richards **within 28 days of purchase**. If you do not register your product within 28 days, it is guaranteed for 2 years. To validate your 3 year guarantee, telephone our consumer helpline. Once you have registered your product, you will receive written confirmation from Morphy Richards, please retain this information. **Please note that the 3 year guarantee is only available in the UK.** Please refer to your 2 year guarantee for more information.

If the fault develops after 28 days and within 24 months of original purchase, you should contact the Helpline number quoting Model number and Serial number on the product, or write to Morphy Richards at the address shown.

You may be asked to return a copy of proof of purchase.

Subject to the exclusions set out below (see Exclusions) the faulty appliance will then be repaired or replaced and dispatched usually within 7 working days of receipt.

If you suspect a fault, follow the simple checks detailed below before retrying the appliance or calling the helpline.

- Check the filters for blockages.
- Check the tools / tubes for blockages.
- Check the plug is firmly in the socket.
- Check the socket is working by trying another appliance.
- Check the fuse in the plug.

If for any reason this item is replaced during the 2 year guarantee period, the guarantee on the new item will be calculated from original purchase date. Therefore it is vital to retain your original till receipt or invoice to indicate the date of initial purchase.

To qualify for the 2 year guarantee, the appliance must have been used according to the instructions supplied.

## YOUR TWO YEAR GUARANTEE



**It is important to retain the retailer's receipt as proof of purchase.** Staple your receipt to this back cover for future reference.

Please quote the following information if the product develops a fault. These numbers can be found on the base of the product.

### Model no.

### Serial no.

All Morphy Richards products are individually tested before leaving the factory. In the unlikely event of any appliance proving to be faulty within 28 days of purchase, it should be returned to the place of purchase for it to be replaced.

Morphy Richards products are intended for household use only.

Morphy Richards has a policy of continuous improvement in product quality and design. The company, therefore reserves the right to change the specification of its models at any time.

## Exclusions

Morphy Richards shall not be liable to replace or repair the goods under the terms of the guarantee where:

- 1 The fault has been caused or is attributable to accidental use, misuse, negligent use or used contrary to the manufacturer's recommendations or where the fault has been caused by power surges or damage caused in transit.
  - 2 The appliance has been used on a voltage supply other than that stamped on the products.
  - 3 Repairs have been attempted by persons other than our service staff (or authorised dealer).
  - 4 Where the appliance has been used for hire purposes or non domestic use.
  - 5 Morphy Richards are not liable to carry out any type of servicing work, under the guarantee.
  - 6 The guarantee excludes consumables such as some filters.
- This guarantee does not confer any rights other than those expressly set out above and does not cover any claims for consequential loss or damage. This guarantee is offered as an additional benefit and does not affect your statutory rights as a consumer.
  - This guarantee is valid in the UK and Ireland only.

**morphy richards**

**The After Sales Division  
Morphy Richards Ltd**  
Mexborough, South Yorkshire,  
England, S64 8AJ

Helpline (office hours)  
UK 0845 077 7700  
Republic of Ireland 1800 409 119

VC71067 MUK Rev 2 10/07

For details of other products in the Morphy Richards range please see our website . . .